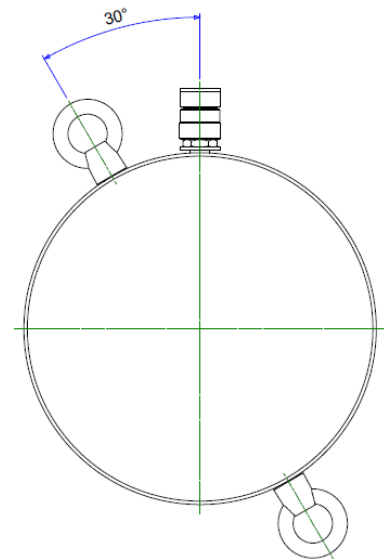

MODEL: CPL-SERIES

- Single Acting - Load Return - Locknut
- Capacity : 60 - 520 Ton
- Stroke : 45mm - 50mm
- Maximum working pressure : 10,000 psi / 700 Bar

FEATURES

- Single Acting Cylinder
- Hard chrome plated piston rod
- Overflow port to prevent over extending piston
- Locknut for safe mechanical load holding
- Low retracted height for use in confined spaces
- Angled coupling for ease of connection

SPECIFICATIONS

Model	Cap Ton	Stroke (mm)	Oil Cap (cc)	Cylinder Effective Area (cm ²)	A Retracted Height (mm)	B Extended Height (mm)	C Outside Dia. (mm)	D Bore Dia. (Ømm)	E Lock Nut Thread (mm)	F (Ømm)	G (mm)	H °	J (mm)	K (mm)	Weight (kg)
CPL602	60	50	432	86.60	125	175	140	105	104 x 4	96	19	5	6	28	15
CPL1002	100	50	734	146.8	137	187	175	136.7	136 x 6	126	21	5	8	31	26
CPL1602	160	45	1040	231.3	148	193	220	171.6	171 x 6	160	27	5	9	40	44
CPL2002	200	45	1285	285.6	155	200	245	190.7	190 x 6	180	30	5	10	43	57
CPL2502	260	45	1650	366.8	159	204	275	216.1	216 x 6	200	32	5	11	44	74
CPL4002	400	45	2517	559.5	178	223	350	266.9	266 x 6	250	39	4	11	55	134
CPL5002	520	45	3287	730.6	192	237	400	305	305 x 6	290	48	3	10	62	189

CPL 2502-5002 and larger capacities are available to order on request